

INCH-POUND

MIL-STD-220B  
24 January 2000  
SUPERSEDING  
MIL-STD-220A  
15 December 1959

**DEPARTMENT OF DEFENSE**  
**TEST METHOD STANDARD**  
**METHOD OF INSERTION LOSS MEASUREMENT**



AMSC N/A

**DISTRIBUTION STATEMENT A.** Approved for public release; distribution is unlimited.

FSC EMCS

## MIL-STD-220B

### FOREWORD

1. This standard is approved for use by all Departments and Agencies of the Department of Defense.
2. This standard specifies a method of measuring the filtering capabilities of passive, low-pass, electromagnetic interference (EMI)/radio-frequency interference (RFI) filters as a function of frequency and considering the influence of temperature and direct current bias. This measurement is known as insertion loss (IL).
3. Filters measured by this method are typically feed-through types, having the live conductor(s) passing through the filter providing both input and output terminals protruding from and insulated from the case which acts as the ground terminal. These filters typically contain capacitors only or capacitors and inductors, and may also contain resistors or diodes. The filters measured to this standard are normally designed for bulkhead mounting, where the input and output terminals are completely isolated from each other by the bulkhead.
4. The test methods in this standard are intended to provide data for quality control during quantity production of filters. The test methods specified with 50 ohm input and output terminations are satisfactory for this purpose; but do not represent conditions that exist in actual circuits or installations. In general, there is little correlation between the MIL-STD-220 quality control tests and the performance of a filter in a particular application. This is because power line filters are normally used under conditions where the power source and load impedances are independent of each other and can vary widely as a function of frequency. In addition, the power source impedance varies from line to line in general practice.
5. Beneficial comments (recommendations, additions, deletions) and any pertinent data which may be of use in improving this document should be addressed to: Defense Supply Center Columbus, Attn: DSCC-VAT, Post Office Box 3990, Columbus, OH 43216-5000, by using the Standardization Document Improvement Proposal (DD Form 1426) appearing at the end of this document or by letter.

MIL-STD-220B

CONTENTS

<u>PARAGRAPH</u>		<u>PAGE</u>
	FOREWORD.....	ii
1.	SCOPE.....	1
1.1	Scope.....	1
2.	APPLICABLE DOCUMENTS.....	1
2.1	General.....	1
2.2	Government documents.....	1
2.2.1	Specifications, standards, and handbooks.....	1
2.3	Non-government publications.....	2
2.4	Order of precedence.....	2
3.	DEFINITIONS.....	2
3.1	Insertion loss.....	2
4.	GENERAL REQUIREMENTS.....	3
4.1	Test setup.....	3
4.1.1	Shielding test.....	3
4.2	Test equipment.....	3
4.2.1	Signal generator.....	3
4.2.2	Receiver.....	4
4.2.3	Coaxial lines, connectors, and switches.....	4
4.2.4	Isolation attenuators.....	4
4.2.5	RF-dc insertion loss measuring equipment assembly.....	4
4.2.5.1	Buffer-network assembly and RF-dc adaptor.....	5
4.2.5.1.1	Buffer-network calibration check.....	5
4.2.5.2	Full-load insertion loss measurements.....	5
4.2.5.3	No-load insertion loss measurements.....	5
4.2.6	Standard attenuator.....	5
4.2.7	Output meter.....	5
5.	METHOD OF TEST.....	6
5.1	Test conditions.....	6
5.2	Test procedure.....	6
5.2.1	Preliminary operation.....	6
5.2.2	Method of measurement.....	6
5.2.2.1	Multiple-circuit components.....	6
5.2.2.2	Test circuit for rapid measurement.....	6
5.2.2.3	Full-load insertion loss measurements.....	6
5.2.2.4	No-load insertion loss measurements.....	6
6.	NOTES.....	7
6.1	Intended use.....	7
6.2	Subject term (key word) listing.....	7
6.3	Changes from previous issue.....	7

MIL-STD-220B

CONTENTS

<u>FIGURE</u>		<u>PAGE</u>
1.	Basic test circuit.....	8
2.	Test circuit for rapid measurement.....	8
3.	Alternate test circuit for rapid measurement.....	8
4.	Basic test circuit for measurement with full load applied.....	9
5.	Test circuit for rapid measurement with full load applied.....	10
6.	Alternate test circuit for rapid measurement with full load applied.....	11
7.	RF-dc insertion loss measuring equipment assembly.....	12-24

## MIL-STD-220B

### 1. SCOPE

1.1 Scope. This standard covers a method of measuring, in a 50 ohm system, the insertion loss of feed-through suppression capacitors, and of single and multiple circuit radio frequency (RF) filters at frequencies up to 10 gigahertz (GHz).

### 2. APPLICABLE DOCUMENTS

2.1 General. The documents listed in this section are specified in sections 3, 4, and 5 of this standard. This section does not include documents cited in other sections of this standard or recommended for additional information or as examples. While every effort has been made to ensure the completeness of this list, document users are cautioned that they must meet all specified requirements documents cited in sections 3, 4, and 5 of this standard, whether or not they are listed.

#### 2.2 Government documents.

2.2.1 Specifications, standards, and handbooks. The following specifications, standards, and handbooks form a part of this document to the extent specified herein. Unless otherwise specified, the issues of these documents are those listed in the issue of the Department of Defense Index of Specifications and Standards (DoDISS) and supplement thereto, cited in the solicitation.

### SPECIFICATIONS

#### DEPARTMENT OF DEFENSE

- MIL-C-17 - Cables, Radio Frequency, Flexible and Semirigid, General Specification For.
- MIL-I-631 - Insulation, Electrical, Synthetic-Resin Composition, Nonrigid.
- MIL-C-11693 - Capacitors, Feed Through, Radio-Interference Reduction, AC and DC (Hermetically Sealed in Metal Cases), Established and Non-Established Reliability, General Specification for.
- MIL-PRF-39012 - Connectors, Coaxial, Radio Frequency, General Specification For.

### STANDARDS

#### DEPARTMENT OF DEFENSE

- MS3452 - Connector, Receptacle, Electric, Box Mounting, Rear Release, Crimp Contact, AN Type With.
- MS3456 - Connectors, Plug, Electrical, Rear Release, Crimp Contact, AN Type.
- MS35214 - Screw, Machine-Pan Head, Cross-Recessed, Brass, UNC-2A.
- MS35273 - Screw, Machine-Drilled Fillister Head, Slotted, Brass, Black Chemical Finish, UNC-2A.
- MS35333 - Washer, Lock, Flat-Internal Tooth.
- MS35338 - Washer, Lock-Spring, Helical, Regular (Medium) Series.
- MS35489 - Grommets, Synthetic and Silicone Rubber, Hot Oil and Coolant Resistant.
- MS90725 - Screw, Cap, Hexagon Head (Finished Hexagon Bolt), Steel, Grade 5, Cadmium Plated, UNC-2A.

(Unless otherwise indicated, copies of federal and military specifications, standards, and handbooks are available from the Defense Automated Printing Service, Building 4D (DPM-DODSSP), 700 Robbins Avenue, Philadelphia, PA 19111-5094.)

## MIL-STD-220B

2.3 Non-Government publications. The following documents form a part of this document to the extent specified herein. Unless otherwise specified, the issues of the documents which are DoD adopted are those listed in the issue of the DoDISS cited in the solicitation. Unless otherwise specified, the issues of documents not listed in the DoDISS are the issues of the documents cited in the solicitation (see 6.2).

### AEROSPACE INDUSTRIES ASSOCIATION

NASM35140 - Strap, Retaining, One Hole for Pipe, Rigid Conduit and Cable.

(Applications for copies should be addressed to Aerospace Industries Association, 1250 Eye Street, N. W., Washington, DC 20005.)

### AMERICAN NATIONAL STANDARDS INSTITUTE

J-STD-006 - Requirements for Electronic Grade Solder Alloys and Fluxed and Non-Fluxed Solders for Electronic Soldering Applications

(Application for copies should be addressed to the American National Standards Institute, 1430 Broadway, New York, NY 10018.)

2.4 Order of precedence. In the event of a conflict between the text of this document and the references cited herein, the text of this document takes precedence. Nothing in this document, however, supercedes applicable laws and regulations unless a specific exemption has been obtained.

## 3. DEFINITIONS

3.1 Insertion loss. At a given frequency, the insertion loss of a feed through suppression capacitor or a filter connected into a given transmission system is defined as the ratio of voltages appearing across the line immediately beyond the point of insertion, before and after insertion. As measured herein, insertion loss is represented as the ratio of input voltage required to obtain constant output voltage, with and without the component, in the specified 50 ohm system. This ratio is expressed in decibels (dB) as follows:

$$\text{Insertion loss} = 20 \log \frac{E_1}{E_2}$$

Where:

$E_1$  = The output voltage of the signal generator with the component in the circuit.

$E_2$  = The output voltage of the signal generator with the component not in the circuit.

When testing is conducted with a network/spectrum analyzer, the equipment usually maintains a constant output voltage and can be set to record the output to input voltage ratio in decibels.

#### 4. GENERAL REQUIREMENTS

4.1 Test setup. The test circuit shall be arranged as shown on figure 1, 2, 3, 4, 5, or 6 whether using individual modules or a network/spectrum analyzer. Using the RF-dc-insertion loss measuring equipment shown in figure 7, or a functionally equivalent input/output isolation fixturing, the test setup shall be capable of indicating a constant value of insertion loss within  $\pm 1.0$  dB over the required frequency range, when the standard attenuator (see 4.2.6) is measured by the method specified in 5.2.2. All test equipment shall be well shielded, and shall be filtered to the extent that leakage, either conducted or radiated, from the signal generator or any portion of the signal source circuitry shall not affect the output of the receiver when the generator and receiver are operating at the output level and sensitivity, respectively, needed to make the required maximum insertion loss measurement. The test setup shall be in accordance with 4.1.1 for each frequency at which an insertion loss measurement is to be made.

Caution: The direct current (dc) source used in making insertion loss measurements with full load applied shall be a floating dc source and shall not be connected to ground.

4.1.1 Shielding test. The following is for testing the signal generator/receiver equipment. With the equipment completely set up for the filter out condition of insertion loss measurement (see 5.2.2), the signal generator shall be disconnected from the powerline, and the receiver gain shall be adjusted to provide a convenient output indication of receiver fluctuation noise. The generator shall then be connected to the power line, and its output voltage ( $E_2$ ) shall be adjusted to provide a receiver output indication of 1.0 dB above that obtained for receiver fluctuation noise. The receiver output indication shall be capable of being adjusted completely down to fluctuation noise by means of the generator output control, that is, in decreasing the generator output, a point shall not be reached at which lowering the output has no further effect on receiver indication while the receiver indication is perceptibly above fluctuation noise. The test setup shall then be connected for the filter in condition by substituting for the component a solid brass or copper plate at least .25 inch thick (6.35 mm) with plane faces at least 2.38 inches (60.45 mm) wide in all directions. This plate shall be placed across the coupler and center conductor of the measuring equipment assembly so that the signal source and load are completely short circuited by the faces of the plate. The output of the generator shall then be raised to the voltage ( $E_1$ ) which causes a receiver- output indication of 1 dB above receiver fluctuation noise. The insertion loss then obtained from the formula (see 3.1) shall be at least 10 dB greater than the insertion loss to be measured. Clamping a copper plate between the end of the output cables that are connected to 50 ohm ports of a network/spectrum analyzer will demonstrate the maximum insertion loss range (dB) on the analyzer's output screen. This maximum insertion loss range shall be at least 10 dB greater than the insertion loss to be measured.

#### 4.2 Test equipment.

4.2.1 Signal generator. After a 30 minute warm-up period, the signal generator shall be capable of maintaining, within  $\pm 1.0$  percent, any frequency to which it may be set, and the output voltage of the generator shall remain constant over any 2 minute test period within  $\pm 1.0$  percent of any value to which it may be set. The generator shall be equipped, either internally or externally, with an attenuator calibrated in terms of output voltage increments and continuously variable from minimum to maximum; calibration shall be accurate within  $\pm 5.0$  percent in dB when the generator is terminated with an impedance of 50 ohms. The output of the generator shall be fitted with or adapted to a coaxial connector in accordance with 4.2.3. When two or more generators are required to cover the specified frequency range, a coaxial switch in accordance with 4.2.3 may be used on the generator side of the isolation attenuator to facilitate changing of generators. When testing is conducted with a network/spectrum analyzer, the equipment shall be capable of meeting the equivalent insertion loss accuracy over the frequency spectrum.

## MIL-STD-220B

4.2.2 Receiver. After a 30 minute warm-up period, the receiver shall be capable of maintaining, within  $\pm 1.0$  percent, any frequency to which it may be tuned, and the overall gain of the receiver shall remain constant over any 2 minute test period, maintaining an output voltage within  $\pm 1.0$  percent of any value to which it may be set. The sensitivity shall be great enough and the level of circuit noise low enough to allow clear reception of the signal required for the measurement. The receiver automatic gain control circuit shall be disabled during measurements, and an output meter shall be used to indicate relative voltage. The input to the receiver shall be fitted with or adapted to a coaxial connector in accordance with 4.2.3. When two or more receivers are required to cover the specified frequency range, a coaxial switch in accordance with 4.2.3 may be used on the receiver side of the isolation attenuator to facilitate changing of receivers. When testing is conducted with a network/spectrum analyzer, the equipment shall be capable of meeting the equivalent insertion loss accuracy over the frequency spectrum.

4.2.3 Coaxial lines, connectors, and switches. All coaxial lines shall be RG-214/U, or equivalent double shielded cable, and shall conform to MIL-C-17. It is essential that cable with the characteristic impedance of type RG-214/U be used to connect the isolation attenuators together for the filter 'out' condition and to connect the component to the isolation attenuators for the filter 'in' condition. The length of cable connecting the isolation attenuators for the filter 'out' condition shall be within  $\pm 6$  inches ( $\pm 152.4$  mm) of the combined length of the two cables connecting the component to the isolation attenuators for the filter 'in' condition. Type N, 50 ohm coaxial connectors conforming to MIL-PRF-39012 shall be used where applicable. When coaxial switches are used, they shall have a 50 ohm characteristic impedance, and a maximum voltage standing wave ratio (VSWR) of 1.1 to 1 at the frequency of measurement.

4.2.4 Isolation attenuators. The isolation attenuators shall be appropriate resistive networks having 50 ohm input and 50 ohm output impedances. The attenuators shall have a minimum insertion loss of 10 dB measured in a 50 ohm system. Looking into either end of each attenuator with the other end terminated in 50 ohms, the VSWR shall be a maximum of 1.1 to 1 up to 400 MHz, and a maximum of 1.2 to 1 from 400 MHz to 1,000 MHz, inclusive. The characteristics of the attenuators shall show no significant change when the system is subjected to the maximum signal generator power required for measurement. The input and output of each attenuator shall be fitted with coaxial connectors in accordance with 4.2.3. These attenuators are for the purpose of obtaining a standard 50 ohm termination for all attenuation measurements. Isolation attenuators are not necessary when testing is conducted using a network/system analyzer that has a 50 ohm input and output ports.

4.2.5 RF-dc insertion loss measurement equipment assembly. When the component under test has no provisions for coaxial connections, the insertion loss measurements shall be recorded after the component's input and output terminals are surrounded by RF shielding that has a common electrical connection with the shielding of the test equipment or test equipment cables. Inserting/clamping a component using a RF-dc-insertion loss equipment assembly shown on figure 7 is an effective method for obtaining input to output RF isolation during a test. When a component has such a shape that it cannot be satisfactorily clamped in the figure 7 assembly, other adequate clamping means shall be used. When using a network/spectrum analyzer, a functionally equivalent isolation fixture shall be used.



## MIL-STD-220B

### 4.2.5.1 Buffer-network assembly and RF-dc adapter.

4.2.5.1.1 Buffer network calibration check. The buffer network calibration can be checked by the following procedure:

- a. Select a 0.1 uF ( $\pm 10$  percent) feedthrough capacitor with a current rating equivalent to the maximum capacity of the buffer networks. The 0.1 uF capacitor is used since it provides sufficient insertion loss performance from 100 kHz to 20 MHz to be used as an effective means for buffer network calibration while not introducing a natural capacitor resonant dip at a frequency below 20 MHz.
- b. Using the test setup shown in figure 1, 2, or 3, record insertion loss performance at 100 kHz, 150 kHz, 300 kHz, 500 kHz, 1 MHz, 10 MHz, and 20 MHz.
- c. Using either the test setup in figures 4 or 5, record insertion loss performance at no-load and maximum load current at 100 kHz, 150 kHz, 300 kHz, 500 kHz, 1 MHz, 10 MHz, and 20 MHz.
- d. The buffer networks are calibrated if the three sets of insertion loss measurements are within 1 dB maximum variation at all test frequencies less than 1 MHz and a 2 dB maximum variation from 1 MHz to 20 MHz.

4.2.5.2 Full-load insertion loss measurements. The buffer-network assembly and RF-dc adapter shown on figure 7, or equivalent, shall be used for providing coaxial connections when performing insertion loss measurements with rated current (dc ratings or equivalent) applied. The complete RF-dc insertion loss measuring equipment assembly, or equivalent, shall be used for test measurements over the frequency range of 100 kHz to 20 MHz, inclusive. The buffer network shown on figure 7 is suitable for continuous use with currents up to 100 amperes.

4.2.5.3 No-load insertion loss measurements. The buffer network assembly shown on figure 7, or its equivalent, shall not be used when performing no-load insertion loss measurements. The RF-dc adapter shown on figure 7, or equivalent, may be used at all frequencies for providing coaxial connections during no-load insertion loss measurements.

4.2.6 Standard attenuator. A standard attenuator for testing with signal-generator/receiver equipment or network/spectrum analyzer shall be provided with the following characteristics:

- a. Attenuation of  $50 \pm 0.5$  dB over the frequency range of 150 kHz to 1,000 MHz, inclusive.
- b. Maximum VSWR of 1.2 to 1 over the frequency range of 150 kHz to 1,000 MHz, inclusive.
- c. Input and output impedance of 50 ohms.

The standard attenuator shall be inserted into the system in place of a component, to test for proper operation as specified in 4.1.

4.2.7 Output meter. An output meter, or similar indicating device, which will provide a readable indication of the magnitude of signal shall be used. The indicating device may be a part of the receiver or a separate instrument connected to the receiver.

## 5. METHOD OF TEST

5.1 Test conditions. Unless otherwise specified in the individual component specification, all measurements shall be made at room ambient temperature, atmospheric pressure, and relative humidity.

### 5.2 Test procedure.

5.2.1 Preliminary operation. To insure stability, each signal generator and receiver shall be operated for a period of at least 30 minutes immediately before measurement.

5.2.2 Method of measurement. The test equipment shall be set up as shown on figure 1, 2, 3, 4, 5, or 6, except that a cable of the type and length specified in 4.2.3 for the filter-out condition shall be inserted between the attenuators to replace the component and its connecting cables. The signal generator shall be adjusted to the desired frequency, with the attenuator set for the lowest convenient value of output voltage. The receiver shall be tuned to resonance at the frequency of the generator, and the gain controls shall be set so that the sensitivity will be great enough and the level of circuit noise low enough to allow clear reception of the signal required for the measurements. The output of the generator ( $E_2$ ) shall be adjusted to give the lowest possible stable and readable indication on the output meter, care being taken not to saturate or overload the receiver. The cable used for the filter out condition shall then be removed, and the component and its connecting cables shall be inserted between the isolation attenuators, with the component connected to the cables as specified in 4.2.5. The receiver shall be returned to resonance, and the output of the generator ( $E_1$ ) adjusted until the output meter gives the same indication as that obtained for the filter-out condition. The insertion loss of the component under the specified conditions and at the frequency of measurement may then be expressed in dB as

$$20 \log \frac{E_1}{E_2}$$

When testing is conducted with a network/spectrum analyzer, insertion loss is read directly from the instrument display.

5.2.2.1 Multiple- circuit components. The insertion loss of each circuit of a multiple-circuit component shall be measured with each of the other circuits open and also with each of the other circuits short circuited; the short circuit connections shall be as short and direct as possible. The insertion loss of the circuit at the frequency of the test shall be considered to be equal to the lesser of the two measurements.

5.2.2.2 Test circuit for rapid measurement. The test circuit for rapid measurement as shown on figure 2, 3, 5, or 6 may be used to facilitate the change from the filter out condition to the filter in condition. The coaxial switches shall be in accordance with 4.2.3.

5.2.2.3 Full-load insertion loss measurements. Full load insertion loss measurements shall be performed as shown on figure 4, 5, or 6 over the frequency range of 100 kHz to 20 MHz, inclusive. The equipment specified in 4.2.5.2 shall be used for coaxial connections. The nominal dc rated current of dc components, or the dc equivalent of the peak alternating current (ac) rated current of ac components shall be applied during these tests.

5.2.2.4 No-load insertion loss measurements. No-load insertion loss measurements shall be performed as shown on figure 1, 2, or 3. The equipment specified in 4.2.5.3 shall be used for coaxial connections.

MIL-STD-220B

6. NOTES

6.1 Intended use. This standard is intended to provide methods for insertion loss measurements of feed-through suppression capacitors and single and multiple-circuit, radio frequency power line filters. These insertion loss measurements are conducted in a 50 ohm system for the purpose of quality control during quantity production.

6.2 Subject term (keyword) listing.

Capacitors, feed-through  
Filters, EMI  
Filters, RFI

6.3 Changes from previous issue. Marginal notations are not used in this revision to identify changes with respect to the previous issue due to the extent of the changes.

Custodians:

Army - CR  
Navy - EC  
Air Force - 11  
DLA - CC

Preparing activity:

DLA - CC

(Project EMCS-0175)

Review activities:

Army - MI  
Navy - YD

MIL-STD-220B

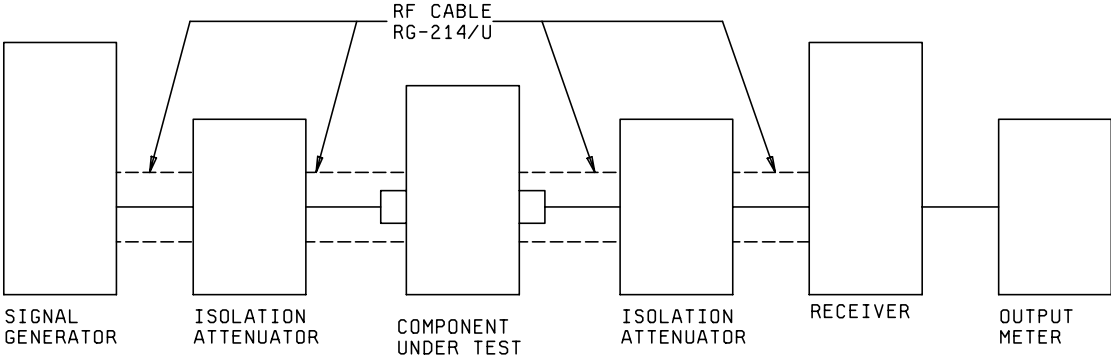

FIGURE 1. Basic test circuit.

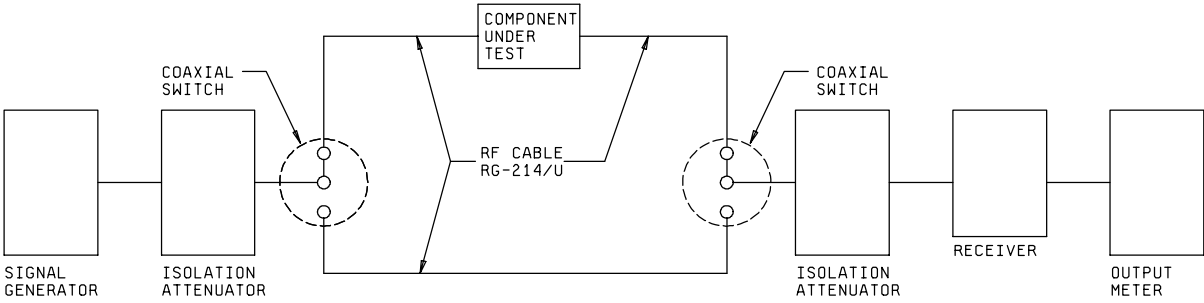

FIGURE 2. Test circuit for rapid measurement.

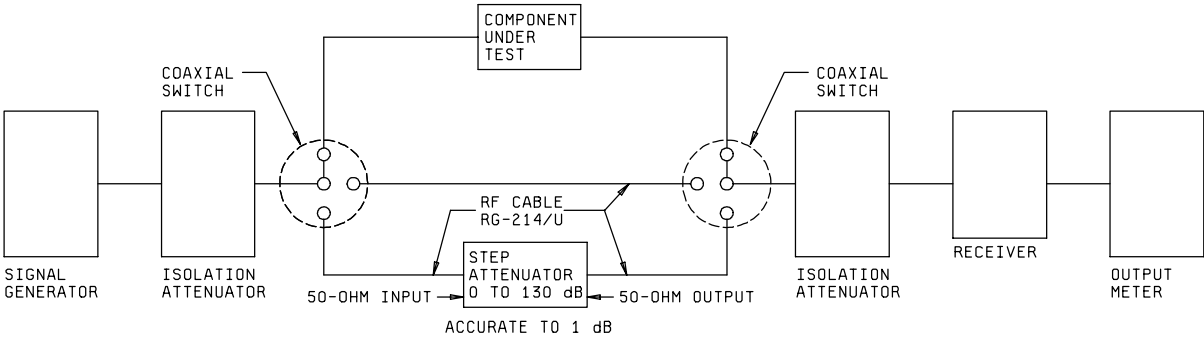

FIGURE 3. Alternate test circuit for rapid measurement.

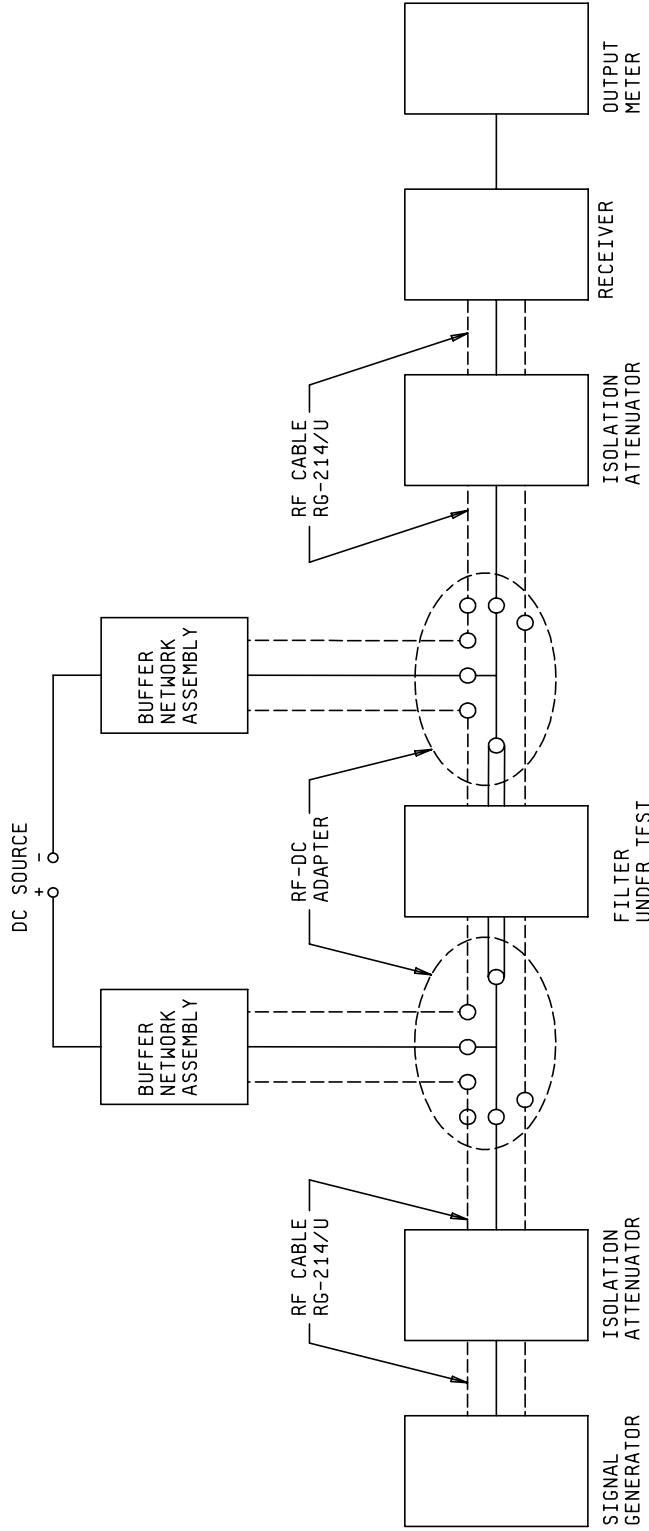

FIGURE 4. Basic test circuit for measurement with full load applied.

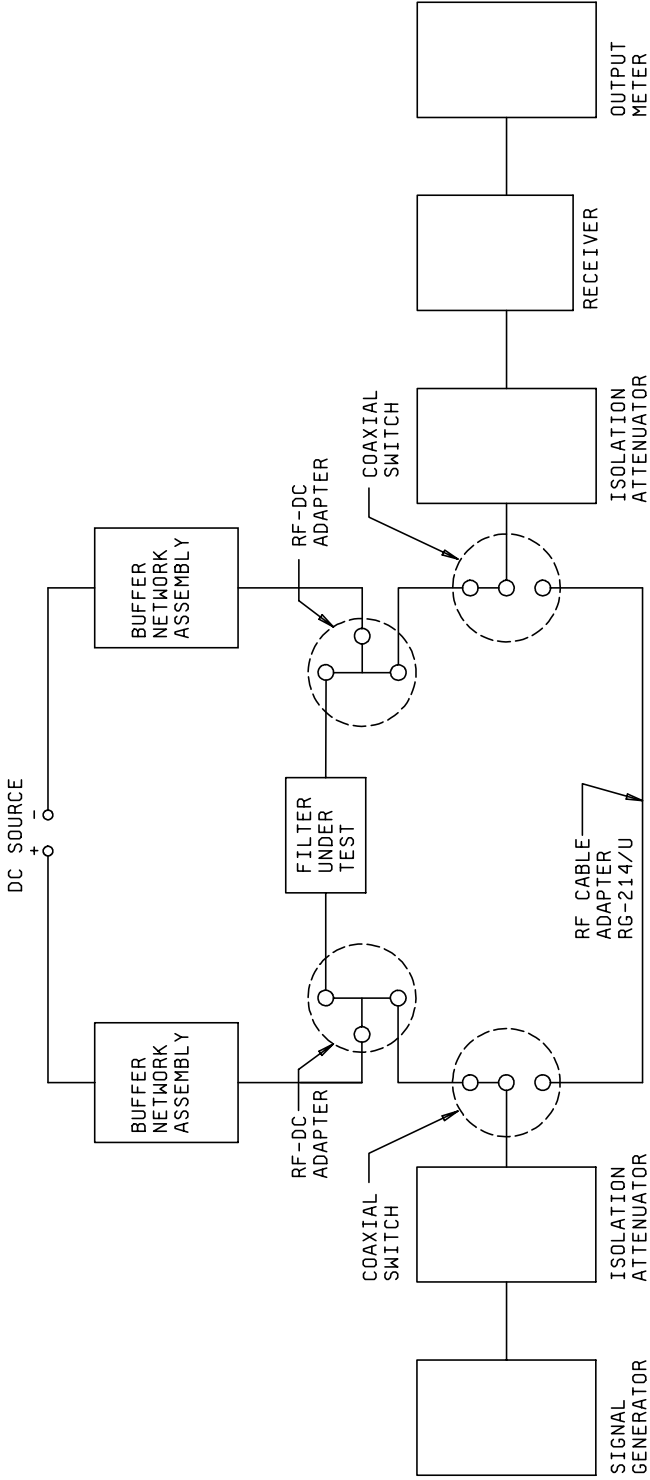

FIGURE 5. Test circuit for rapid measurement with full load

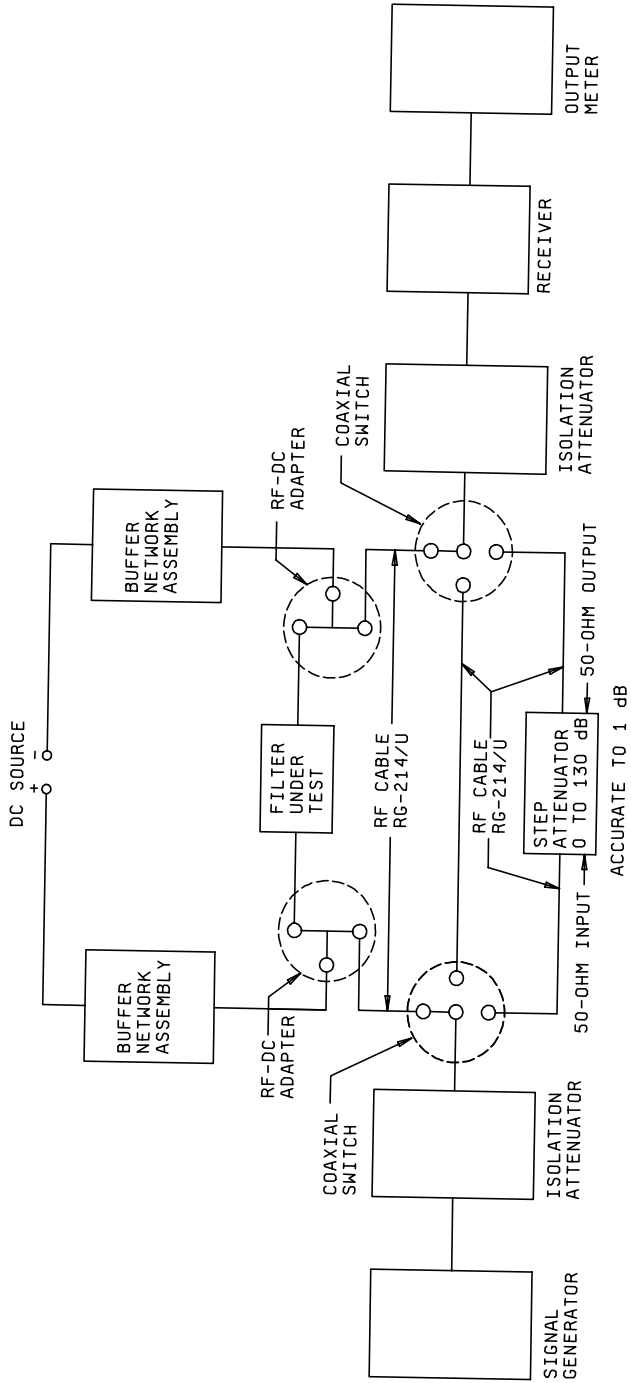

FIGURE 6. Alternate test circuit for rapid measurement with full load applied.

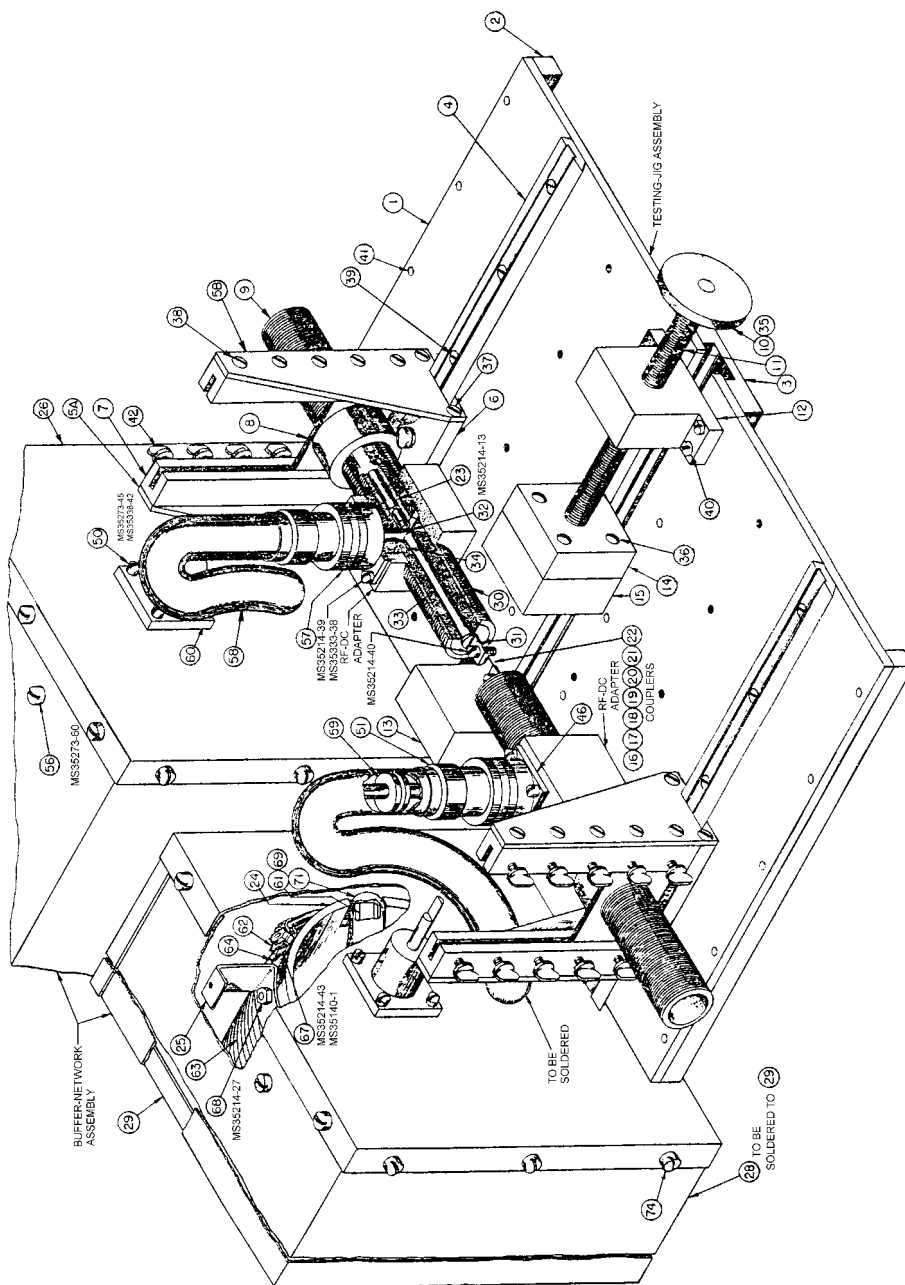

FIGURE 7. RF-Dc insertion loss measuring equipment assembly.



MIL-STD-220B

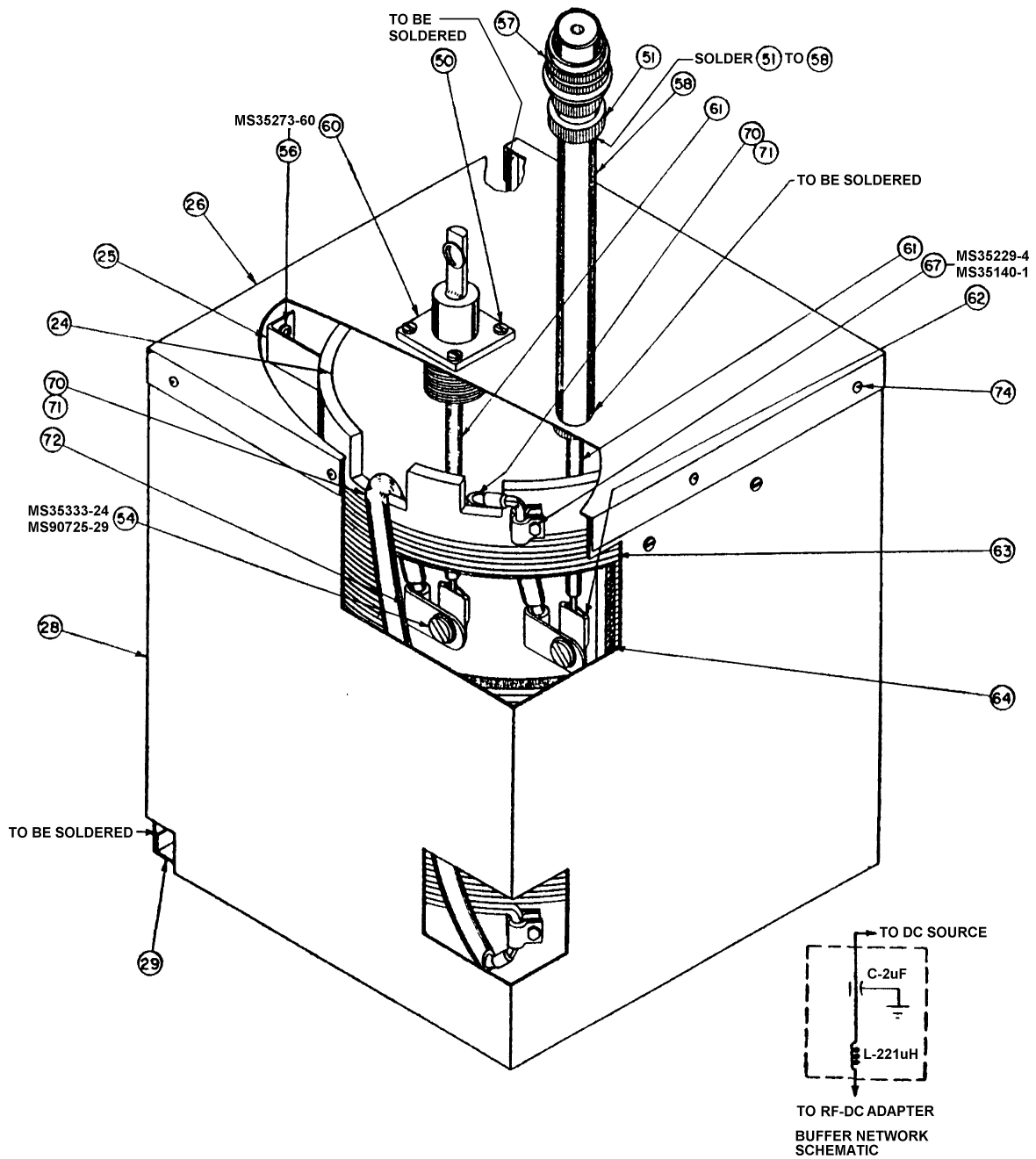

FIGURE 7. RF-Dc insertion loss measuring equipment assembly - Continued.

## MIL-STD-220B

Item No. or MS PIN	Description	Material	Quantity
1	Plate	Brass (chrome plated)	2
2	Bar		2
3	Channel		1
4	Track		2
5A	Right plate		2
5B	Left plate		2
6	Runner		2
7	Bar		4
8	Eye		2
9	Tube		2
10	Knob		1
11	Shaft	Steel (chrome plated)	1
12	Front block	Brass (chrome plated)	1
13	Rear block		1
14	Block		1
15	Block		1
16	Coupler		2
17	Coupler		2
18	Coupler		2
19	Coupler		2
20	Coupler		2
21	Coupler		2
22	Coupler		2
23	Connector	2	
24	Coil form	Plastic	2
25	Bracket	Brass	8
26	Cover	Copper (1 side tinned)	2
28	Case		2
29	Bottom panel	Brass (chrome plated)	2
30	Adapter body		2
31	Conductor	Copper (silver plated)	2
32	Conductor	Acrylic plastic	2
33	Insulator		2
34	Insulator	Steel	2
35	Set screw, cup point No. 8-32 NC-2A, 1.25 lg.		1
36	Screw, RHMS, No. 10-32 NF-2A, 1.25 lg.		4
37	Screw, FHMS, No. 8-32 NC-2A, .50 lg.		8
38	Screw, FHMS, No. 10-32 NF-2A, .312 lg.		20
39	Screw, FHMS, No. 10-32 NF-2A, .375 lg.		Brass (zinc or cadmium plated)
40	Screw, FIL HMS, No. 10-32 NF-2A, .625 lg.	6	
41	Screw, FHMS, No. 10-32 NF-2A, .750 lg.	20	
42	Screw, thumb shoulder, No. 10-24, NC-2A, .50 lg.	24	
46	Receptacle, in accordance with MS3452W18-5S	-----	2
50	Hex nut, No. 8-32 NC-2B	-----	8
51	Nut, in accordance with U-4864-3B Titeflex Corp., or equivalent	-----	2
54	Hex nut, No. 18 UNC-2B	Steel	4
56	Hex nut, No. 10-24 NC-2B	Brass	16
57	Connector, in accordance with MS3456W18-6S	-----	2
58	Conduit shielding, 8.625 lg.	-----	2
59	Grommet, in accordance with MS35489-67	-----	8
60	Capacitor, feed-through, 2 $\mu$ F, 100 V dc, 200A, in accordance with MIL-C-11693	-----	2
61	Cable, 6 tw, 600 volt	-----	as required
62	Terminal	-----	4

FIGURE 7. RF-Dc insertion loss measuring equipment assembly - Continued.

MIL-STD-220B

Item No. or MS PIN	Description	Material	Quantity
63	Coil, No. 6 rectangular formex wire (wound 2 layers for total of 48 turns)	-----	As req'd
64	Kraft paper	-----	As req'd (use optional)
67	Hex nut, No. 8-32 NC-2B	Brass	8
68	Hex nut, No. 6-32 NC-2B		16
69	Terminal	Copper, (hot-tin dipped)	2
70	Cable, ¼ braided, 2 pcs 5 ½ lg, 2 pcs 16 ½ lg.	Copper	
71	Insulation, in accordance with MIL-I-631, 2 pcs, 5.125 lg., 2 pcs 16.125 lg.	Vinyl	
72	Terminal	Copper	4
74	Screw, self tapping, FIL H , No. 6, type B, .375 lg.	Steel	24
MS35140-1	Strap, retaining		8
MS35214-4	Screw	Brass	1
MS35214-13	Screw		1
MS35214-27	Screw		16
MS35214-39	Screw		8
MS35214-40	Screw		2
MS35214-43	Screw		4
MS35273-45	Screw		8
MS35273-60	Screw		16
MS90725-29	Screw		4
MS35333-24	Lockwasher		Steel
MS35333-38	Lockwasher	8	
MS35338-42	Lockwasher	8	

FIGURE 7. RF-Dc insertion loss measuring equipment assembly - Continued.

MIL-STD-220B

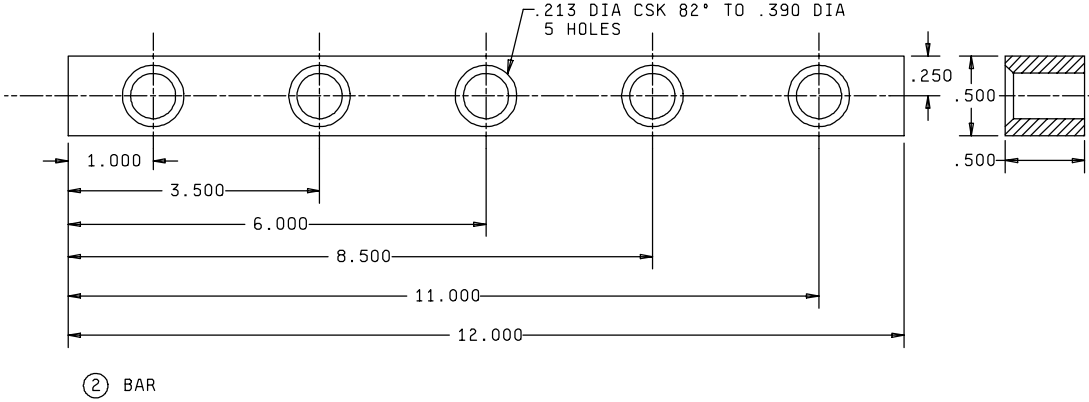
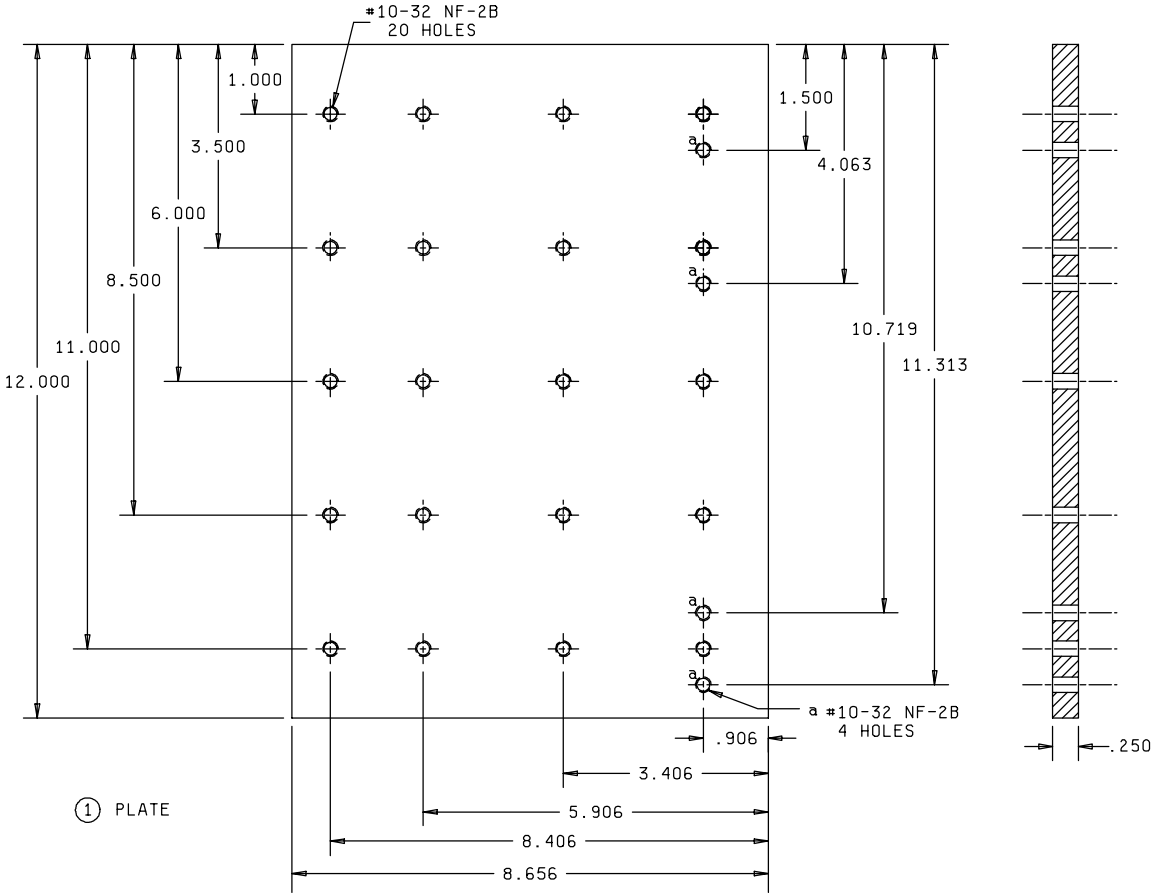

FIGURE 7. RF-dc insertion loss-measuring equipment assembly - Continued.

MIL-STD-220B

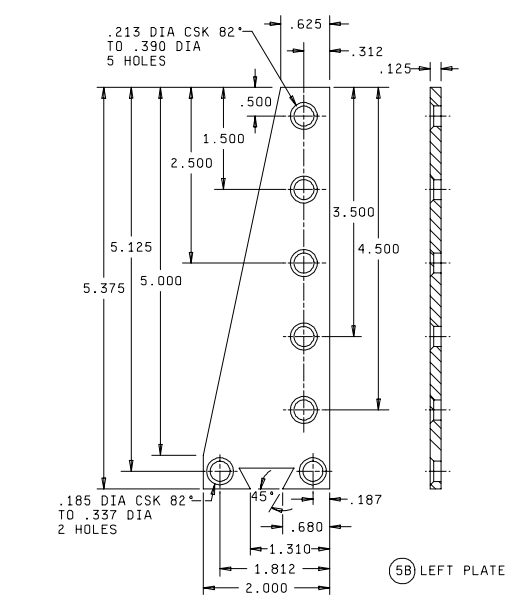
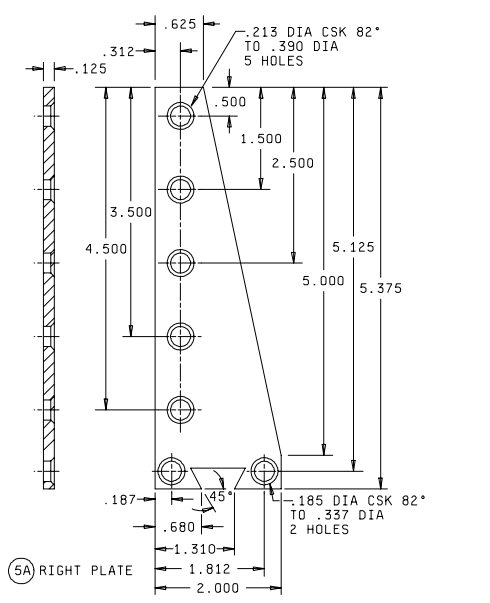
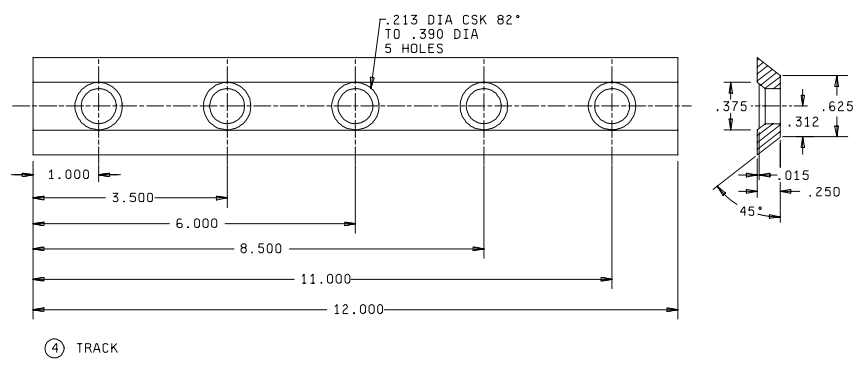
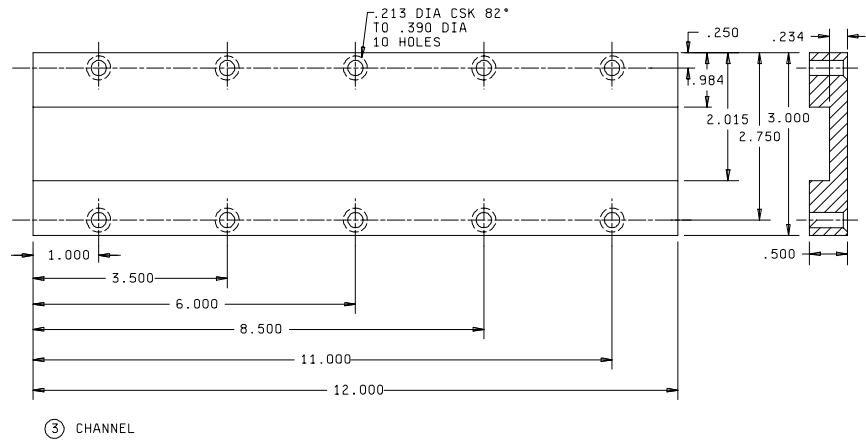

FIGURE 7. RF-dc insertion loss measuring equipment assembly - Continued.

MIL-STD-220B

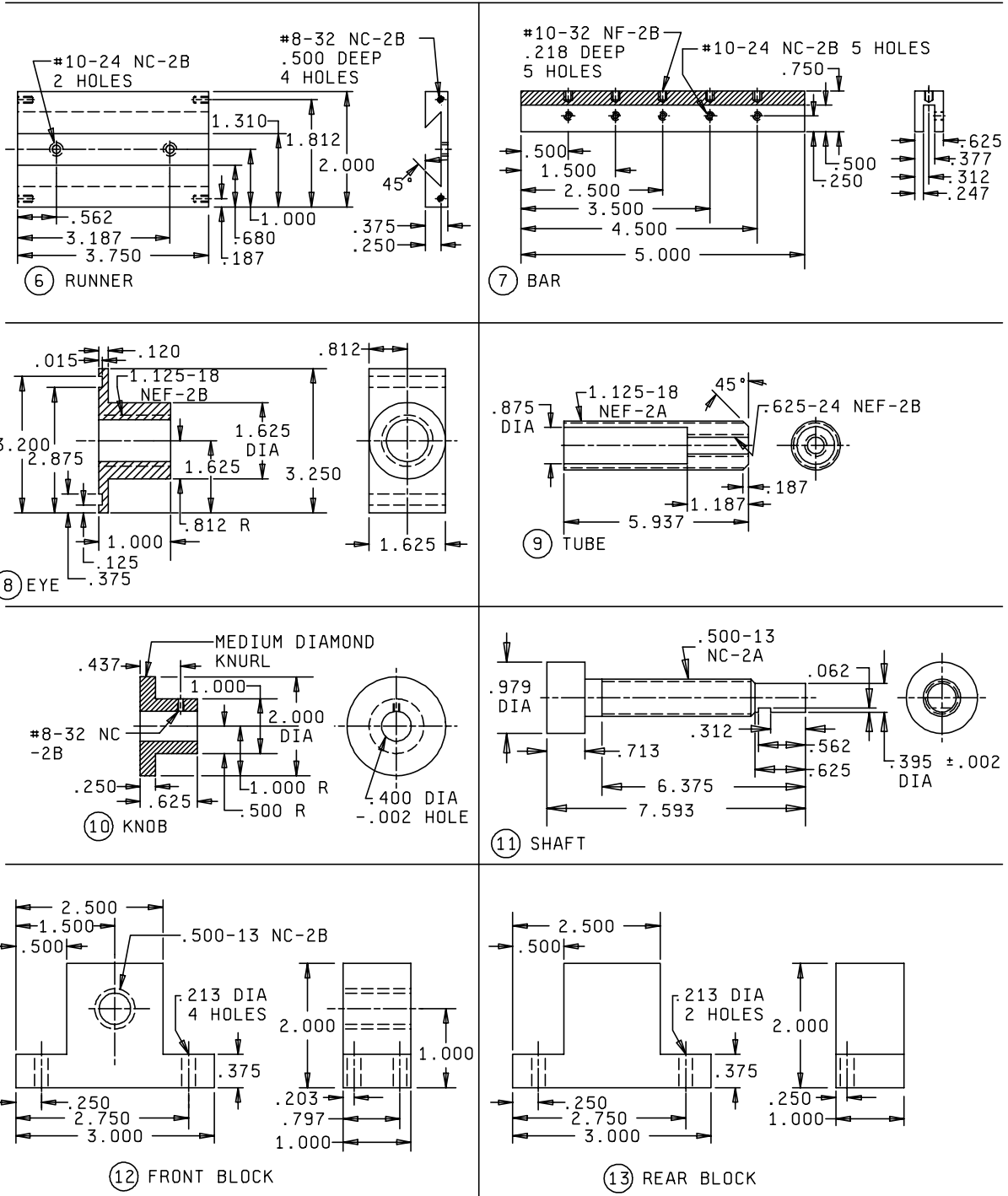

FIGURE 7. RF-Dc insertion loss measuring equipment assembly - Continued.

MIL-STD-220B

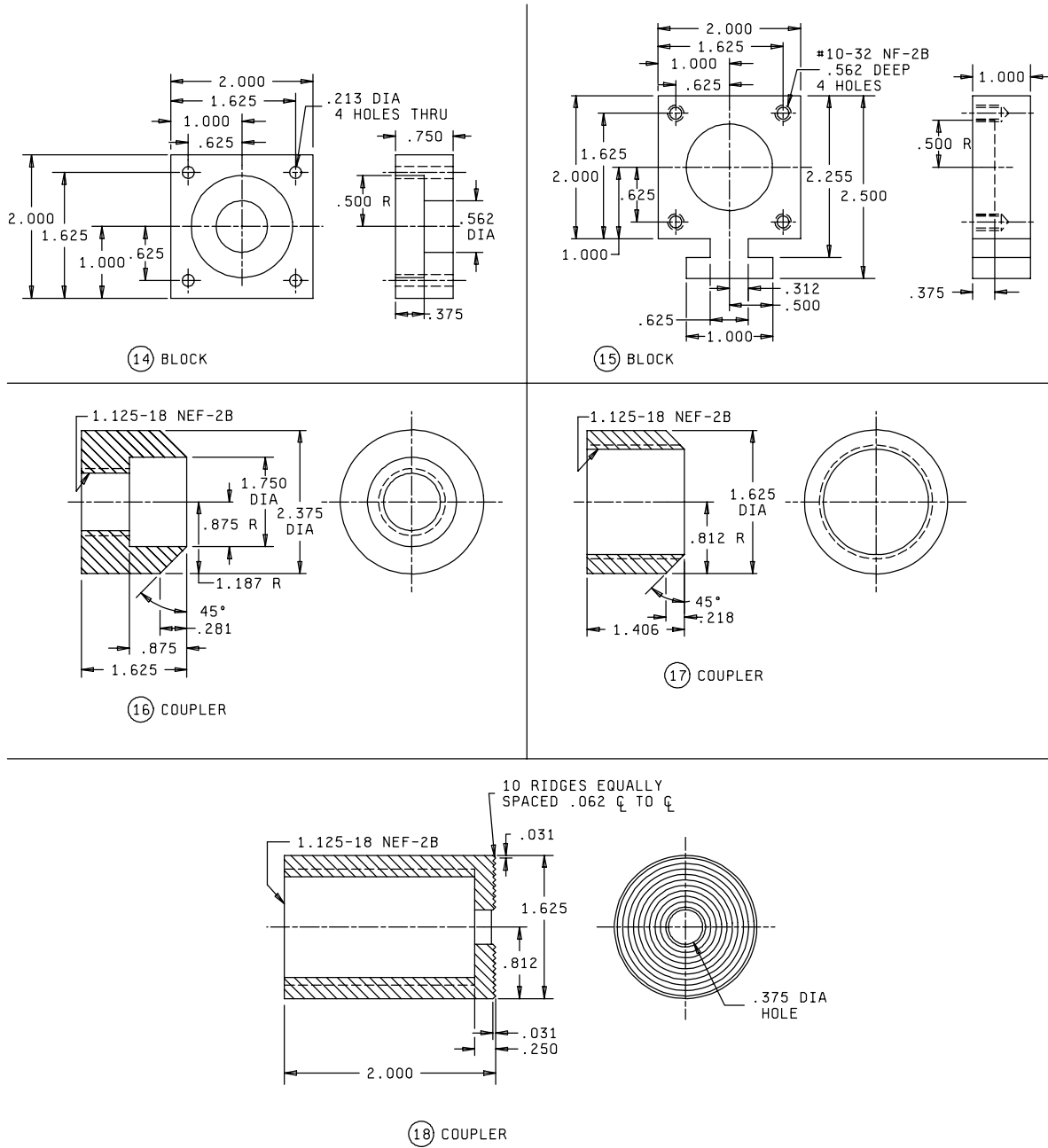

FIGURE 7. RF-Dc insertion loss measuring assembly - Continued.

MIL-STD-220B

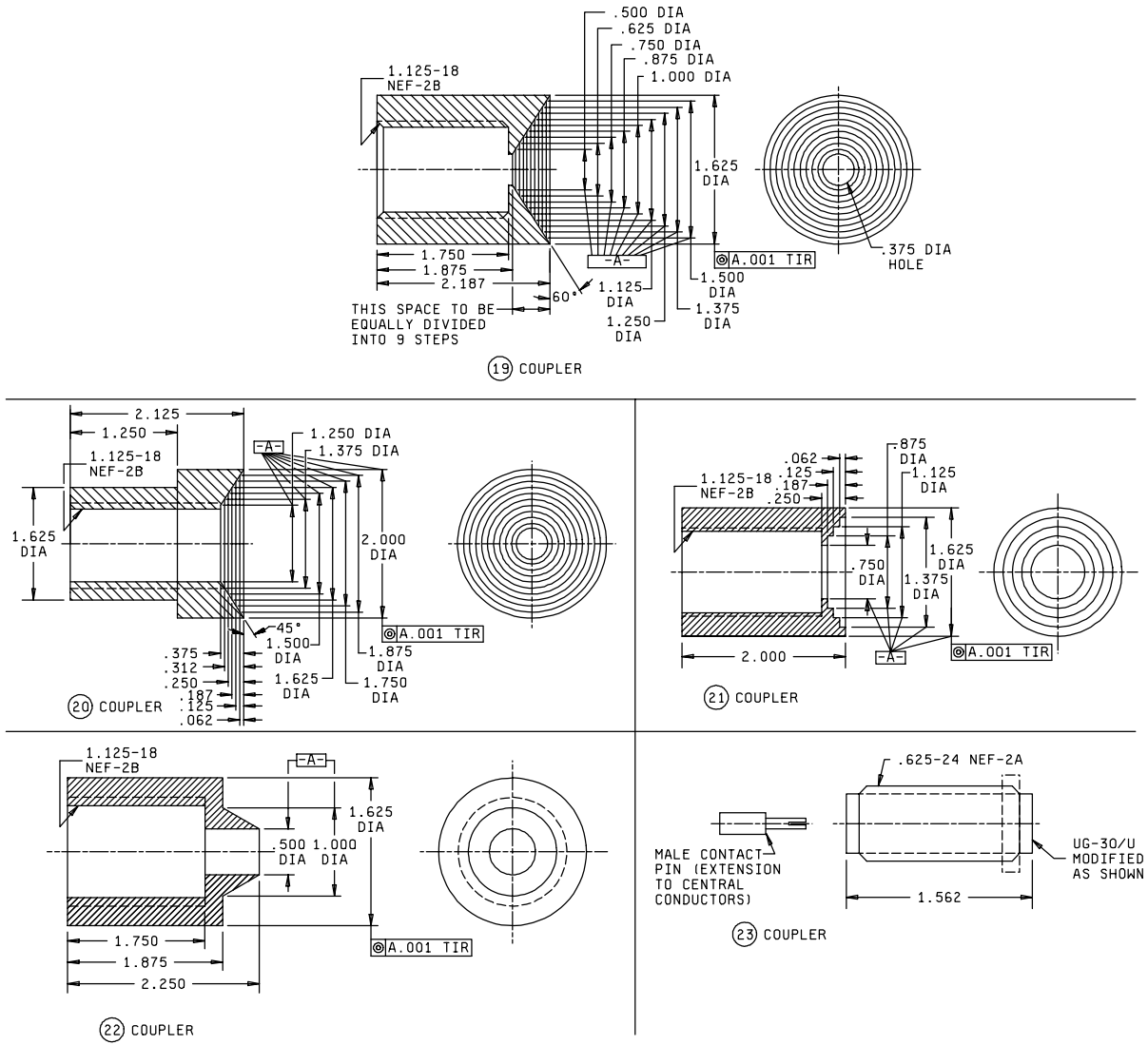

FIGURE 7. RF-Dc insertion loss measuring assembly - Continued.



MIL-STD-220B

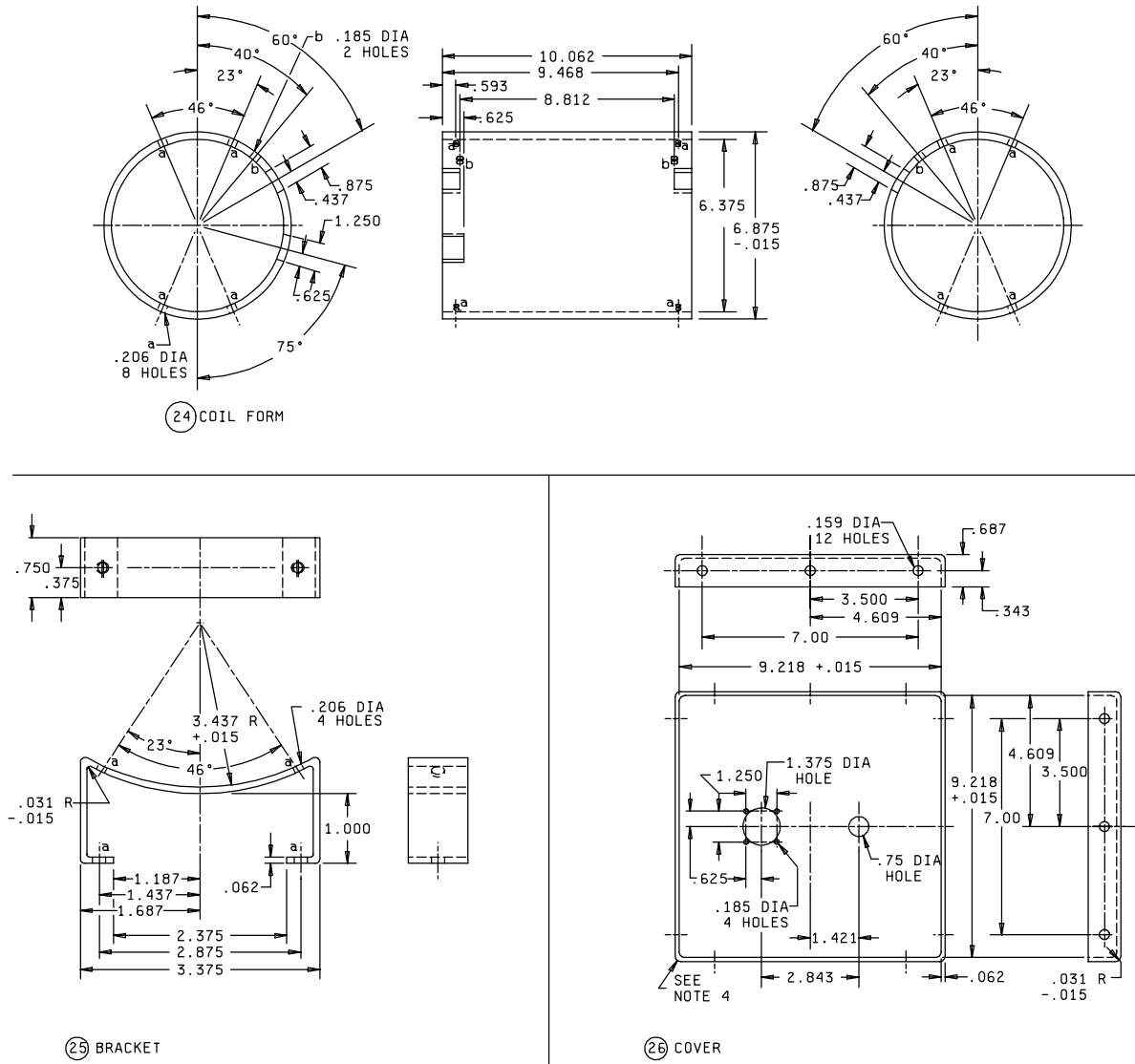

FIGURE 7. RF-Dc insertion loss measuring equipment assembly - Continued.

MIL-STD-220B

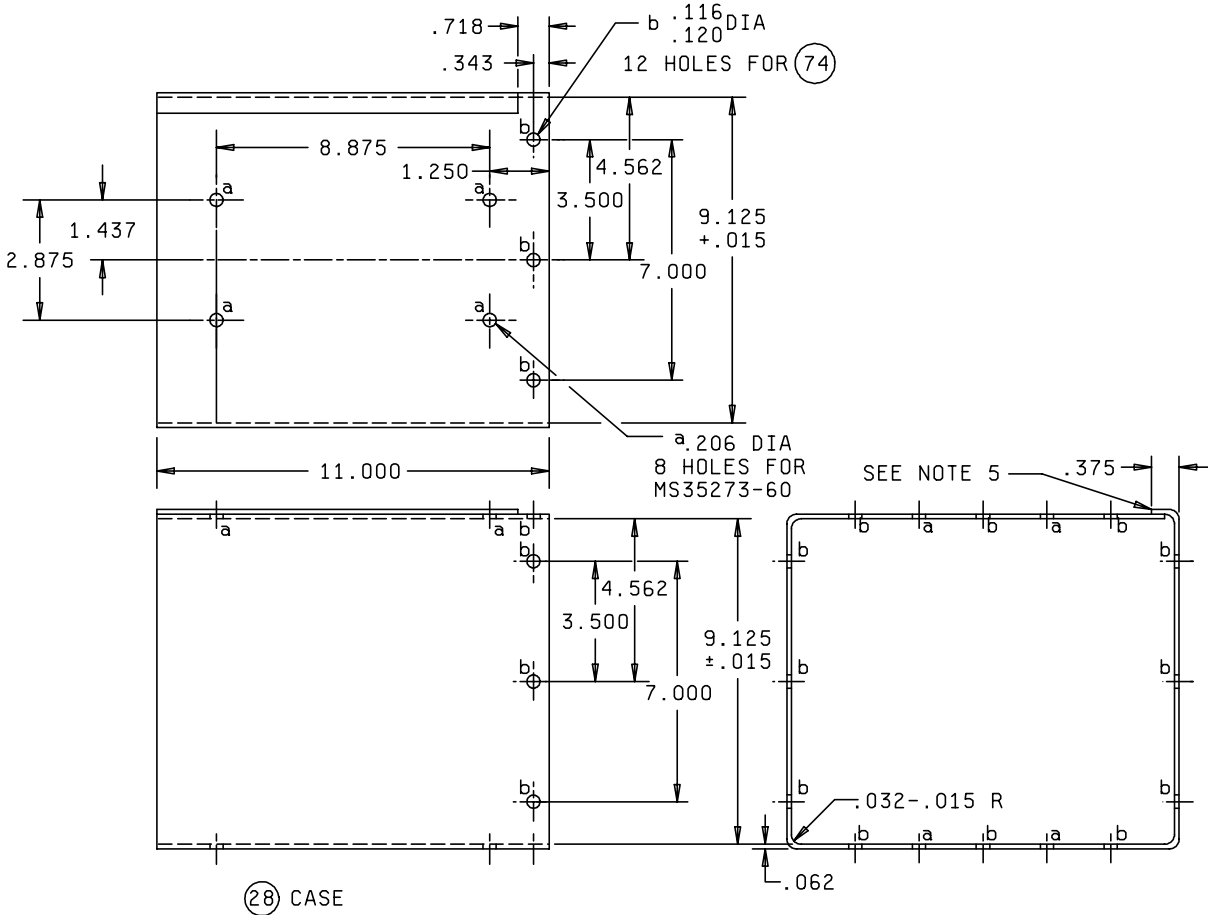

FIGURE 7. RF-Dc insertion loss measuring equipment assembly - Continued.

MIL-STD-220B

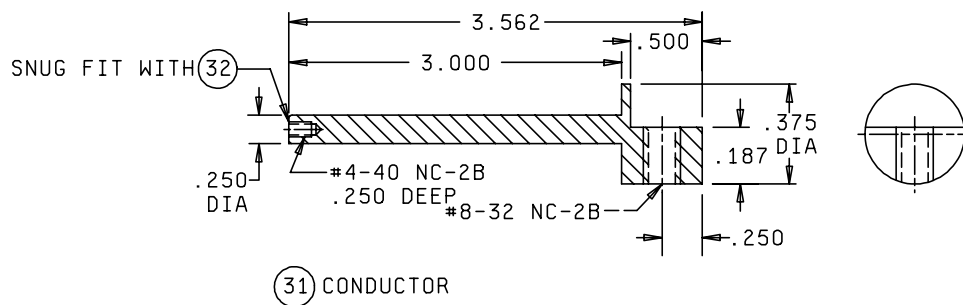
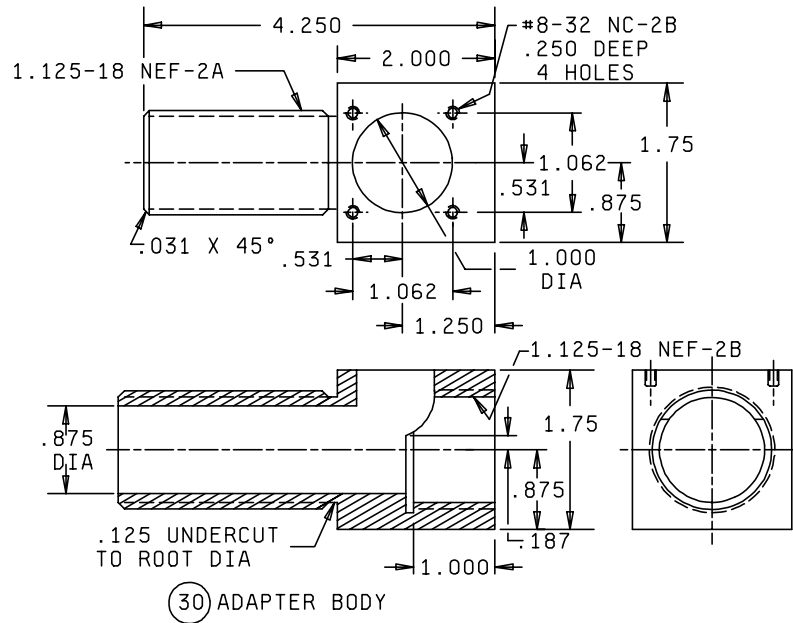
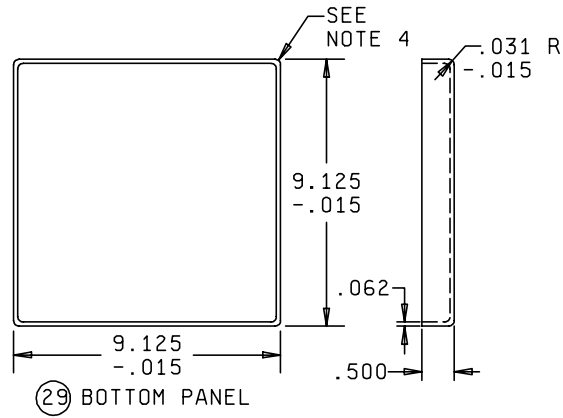
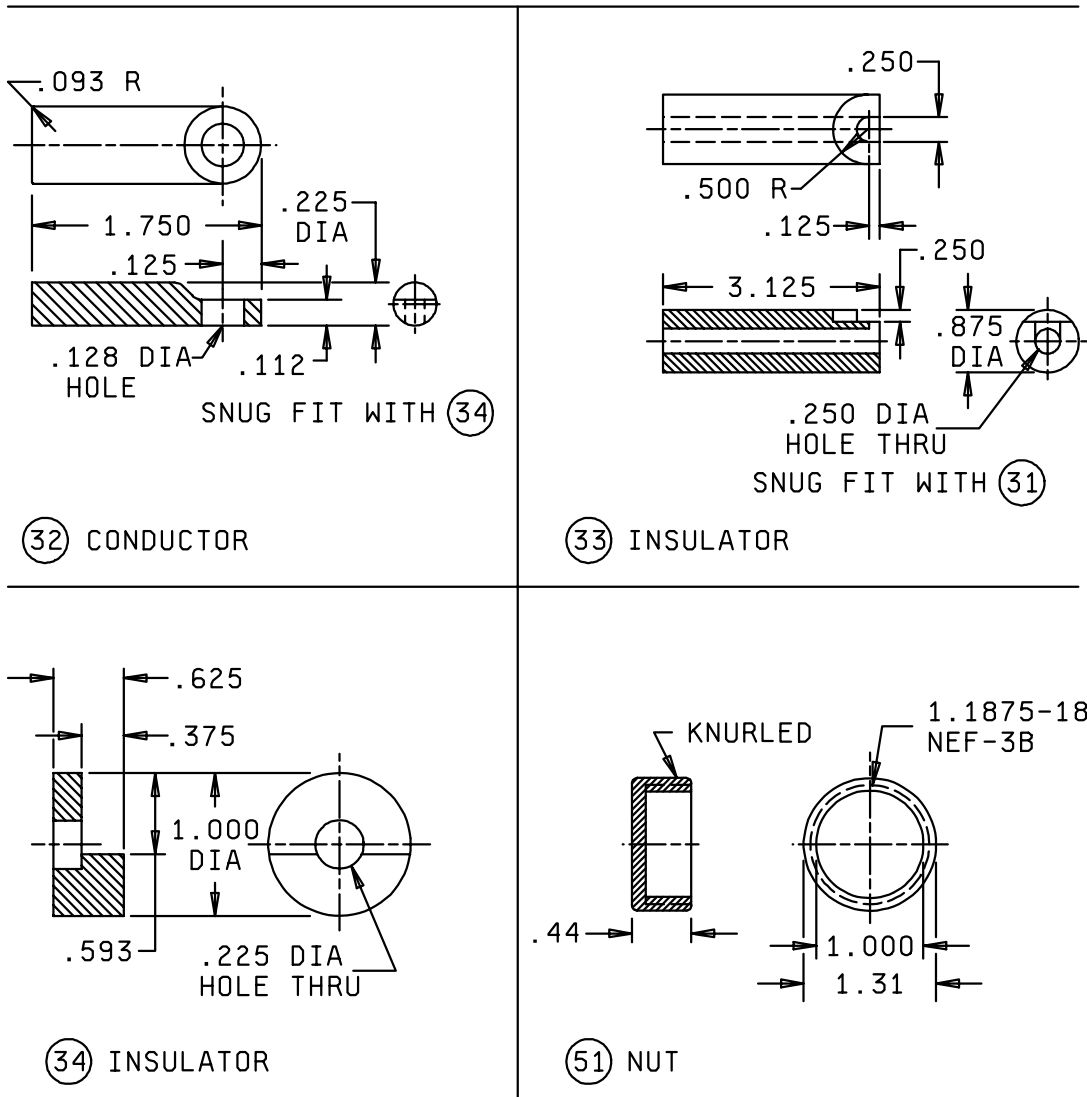

FIGURE 7. RF-Dc insertion loss measuring equipment assembly - Continued.



NOTES:

1. All dimensions are in inches.
2. Unless otherwise specified, tolerances are  $\pm .005$  on decimals, and  $\pm 1^\circ$  on angles.
3. Solder used shall be Sn40A or Pb60A of J-STD-006.
4. Corners shall be soldered and then rounded.
5. The edge shall be securely soldered.

FIGURE 7. RF-Dc insertion loss measuring equipment assembly - Continued.

## STANDARDIZATION DOCUMENT IMPROVEMENT PROPOSAL

### INSTRUCTIONS

1. The preparing activity must complete blocks 1, 2, 3, and 8. In block 1, both the document number and revision letter should be given.
2. The submitter of this form must complete blocks 4, 5, 6, and 7.
3. The preparing activity must provide a reply within 30 days from receipt of the form.

NOTE: This form may not be used to request copies of documents, nor to request waivers, or clarification of requirements on current contracts. Comments submitted on this form do not constitute or imply authorization to waive any portion of the referenced document(s) or to amend contractual requirements.

<b>I RECOMMEND A CHANGE:</b>	<b>1. DOCUMENT NUMBER</b> MIL-STD-220	<b>2. DOCUMENT DATE</b>
<b>3. DOCUMENT TITLE</b> TEST METHOD STANDARD, METHOD OF INSERTION LOSS MEASUREMENT		
<b>4. NATURE OF CHANGE</b> <i>(Identify paragraph number and include proposed rewrite, if possible. Attach extra sheets as needed.)</i>		
<b>5. REASON FOR RECOMMENDATION</b>		
<b>6. SUBMITTER</b>		
a. NAME (Last, First, Middle initial)	b. ORGANIZATION	
c. ADDRESS (Include Zip Code)	d. TELEPHONE (Include Area Code) Commercial DSN FAX EMAIL	7. DATE SUBMITTED
<b>8. PREPARING ACTIVITY</b>		
a. Point of Contact Patrick Kyne	b. TELEPHONE Commercial      DSN      FAX      EMAIL 614-692-0562      850-0562      614-692-6939      Patrick_Kyne@dsccl.dla.mil	
c. ADDRESS Defense Supply Center Columbus ATTN: DSCC-VAT Columbus, OH 43216-5000	<b>IF YOU DO NOT RECEIVE A REPLY WITHIN 45 DAYS, CONTACT:</b> Defense Standardization Program Office (DLSC -LM) 8725 John J. Kingman Road, Suite 2533 Fort Belvoir, Virginia 22060-6221 Telephone (703) 767-6888      DSN 427-6888	