

RECEIVER TYPES AND CHARACTERISTICS

Besides the considerations of noise and noise figure, the capabilities of receivers are highly dependant on the type of receiver design. Most receiver designs are trade-offs of several conflicting requirements. This is especially true of the Electronic Support Measures (ESM) receivers used in Electronic Warfare.

This section consists of a figure and tables that provide a brief comparison of various common ESM receiver types. Figure 1 shows block diagrams of four common ESM receivers. Table 1 is a comparison of major features of receivers. Table 2 shows the receiver types best suited for various types of signals and Tables 3 and 4 compare several direction of arrival (DOA) and emitter location techniques. Table 5 shows qualitative and quantitative comparisons of receiver characteristics.

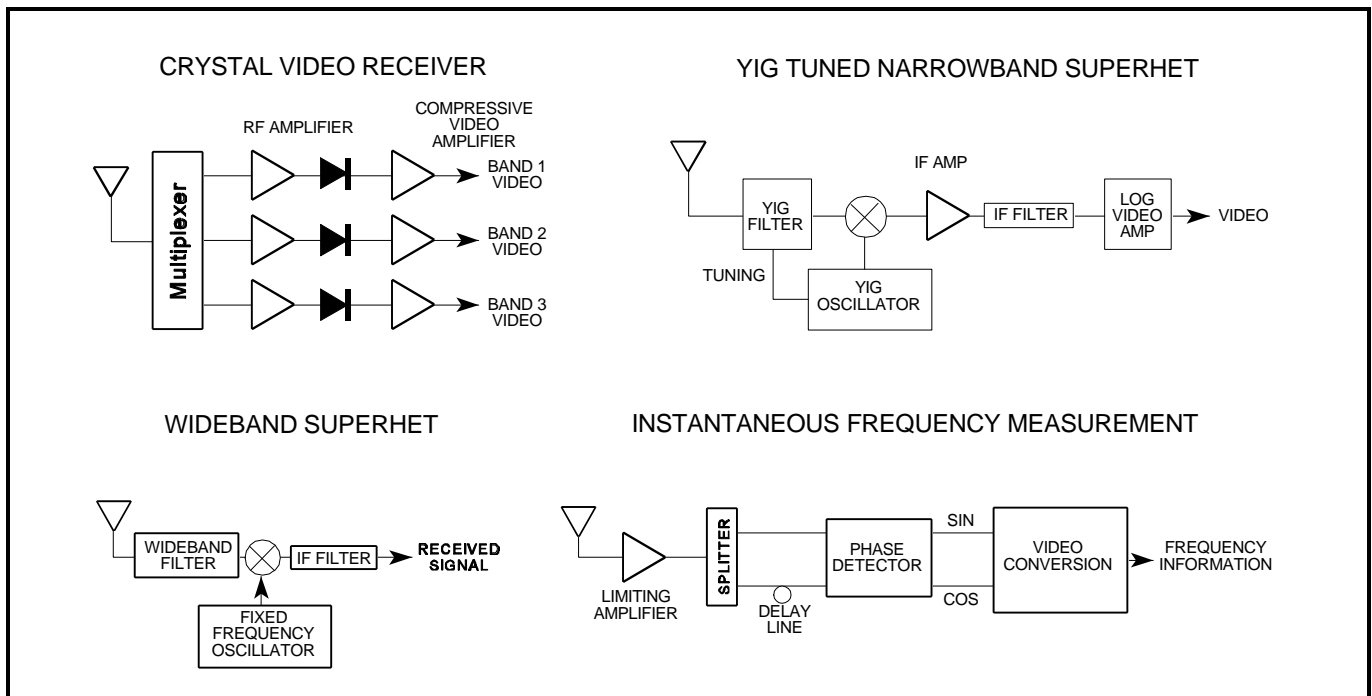

Figure 1. Common ESM Receiver Block Diagrams

Table 1. Comparison of Major Features of Receivers

Receiver	Advantages	Disadvantages	Principal Applications
Wideband crystal video	Simple, inexpensive, instantaneous, High POI in frequency range	No frequency resolution Poor sensitivity and Poor simultaneous signal performance	RWR
Turned RF Crystal Video	Simple, Frequency measurement Higher sensitivity than wideband	Slow response time Poor POI	Option in RWR, Frequency measurement in hybrid
IFM	Relatively simple Frequency resolution Instantaneous, high POI	Cannot sort simultaneous signals Relatively poor sensitivity	Shipboard ESM, Jammer power management, SIGINT equipment
Narrow-band scanning Superhet	High sensitivity Good frequency resolution Simultaneous signals don't interfere	Slow response time Poor POI Poor against frequency agility	SIGINT equipment Air and ship ESM Analysis part of hybrid
Wide-band Superhet	Better response time and POI	Spurious signals generated Poorer sensitivity	Shipboard ESM Tactical air warning
Channelized	Wide bandwidth, Near instantaneous, Moderate frequency resolution	High complexity, cost; Lower reliability; limited sensitivity	SIGINT equipment Jammer power management
Microscan	Near instantaneous, Good resolution and dynamic range, Good simultaneous signal capability	High complexity, Limited bandwidth No pulse modulation information Critical alignment	SIGINT equipment Applications for fine freq analysis over wide range
Acousto-optic	Near instantaneous, Good resolution, Good simultaneous signal capability Good POI	High complexity; new technology	

Table 2. Receiver Types vs. Signal Types

Signal Type	Receiver Type							
	Wide-Band Crystal Video	TRF Crystal Video	IFM	Narrow-Band Superhet	Wide-Band Superhet	Channelized	Microscan	Acousto-optic
CW	Special design for CW	Special design for CW	Yes, but interferes with pulsed reception	Yes	Yes	Yes	Yes	Yes
Pulsed	Yes	Yes	Yes	Yes	Yes	Yes	Yes	Yes
Multiple Frequency	No	No	No	Yes, but won't recognize as same source	No	Yes	Yes	Yes
Frequency Agile	Yes, doesn't measure frequency	No	Yes	No	Yes (within passband)	Yes	Yes	No/Yes, depending on readout time
PRI Agile	Yes	Yes	Yes	No/Yes, depending on scan rate	Yes	Yes	No/Yes, imprecision in TOA	No/Yes, depending on readout time
Chirped	Yes, within acceptance BW	No	Yes	No/Yes, depending on BW	Yes	Yes (reduced sensitivity)	No/Yes, depending on scan rate	Yes (reduced sensitivity)
Spread Spectrum	Yes, within acceptance BW	No	Yes	No	No/Yes, depending on BW	Yes (reduced sensitivity)	Yes (reduced sensitivity)	Yes (reduced sensitivity)

Table 3. Direction of Arrival Measurement Techniques

	Amplitude Comparison	Phase Interferometer
Sensor Configuration	Typically 4 to 6 Equal Spaced Antenna Elements for 360° Coverage	2 or more RHC or LHC Spirals in Fixed Array
DF Accuracy	$DF_{ACC} \approx \frac{\Theta_{bw}^2 \Delta C_{dB}}{24 S}$ (Gaussian Antenna Shape)	$DF_{ACC} \approx \frac{\lambda}{2 \pi d \cos\theta} \Delta\theta$
DF Accuracy Improvement	Decrease Antenna BW; Decrease Amplitude Mistrack; Increase Squint Angle	Increase Spacing of Outer Antennas; Decrease Phase Mistrack
Typical DF Accuracy	3° to 10° rms	0.1° to 3° rms
Sensitivity to Multipath/Reflections	High Sensitivity; Mistrack of Several dB Can Cause Large DF Errors	Relatively Insensitive; Interferometer Can be Made to Tolerate Large Phase Errors
Platform Constraints	Locate in Reflection Free Area	Reflection Free Area; Real Estate for Array; Prefers Flat Radome
Applicable Receivers	Crystal Video; Channelizer; Acousto-Optic; Compressive; Superheterodyne	Superheterodyne
ΔC_{dB} = Amplitude Monopulse Ratio in dB S = Squint Angle in degrees θ_{BW} = Antenna Beamwidth in degrees		

Table 4. Emitter Location Techniques

Measurement Technique	Advantages	Disadvantages
Triangulation	Single Aircraft	Non-instantaneous location Inadequate accuracy for remote targeting Not forward looking
Azimuth/elevation	Single Aircraft Instantaneous location possible	Accuracy degrades rapidly at low altitude Function of range
Time Difference of Arrival (Pulsed signals)	Very high precision Can support weapon delivery position requirements Very rapid, can handle short on-time threat	Very complex, diverse systems required, at least 3 aircraft High quality receivers, DME (3 sites) very wideband data link Very high performance control processor; requires very high reliability subsystems

Table 5. Qualitative Comparison of Receivers

From NRL Report 8737

Feature	Receiver Type							
	Wide-Band Crystal Video	TRF Crystal Video	IFM	Narrow-Band Superhet	Wide-Band Superhet	Channelized	Microscan	Acousto-optic
Instantaneous Analysis Bandwidth	Very wide	Narrow	Very wide	Narrow	Moderate	Wide	Wide	Moderate
Frequency Resolution	Very poor	Fair	Good	Very good	Poor	Fair	Good	Good
Sensitivity	Poor (No preamp) Fair (preamp)	Fair/ good	Poor (No preamp) Fair (preamp)	Very good	Fair	Fair/ good	Very good	Good
Dynamic Range	Fair	Fair/ good	Good	Very good	Fair	Good	Fair	Poor
Speed of Acquisition	Very Fast	Slow	Very Fast	Slow	Fast	Very Fast	Very Fast	Fast
Short pulse Width Capability	Good	Good	Good	Good	Very good	Good	Fair	Fair
Retention of Signal Characteristics	Fair	Fair	Poor	Good	Fair/ good	Good	Poor	Fair/ good
Applicability to Exotic Signals	Poor/ fair	Poor	Good	Poor	Fair/ good	Good	Fair/ good	Fair/ good
High signal Density Performance	Poor (high false alarm rate from background)	Fair/ good	Good	Poor	Fair (depending on BW)	Fair/good, depending on architecture & processing	Good	Poor
Simultaneous Signal Capability	Poor	Fair/ good	Poor	Good	Fair (depending on BW)	Good	Good	Good
Processing Complexity	Moderate depending on application	Moderate depending on application	Moderate	Moderate	Moderate	Low-high depending on architecture	Complex	Simple signal processing complex data processing
Immunity to Jamming	Poor	Fair	Poor/ Fair	Good	Poor/ Fair	Good	Good	Good
Power Requirements	Low	Low/ Moderate	Moderate	Moderate	Moderate	High	Moderate	Moderate/ High
RF Range (GHz)	Multi-octave (0.5-40)	0.15-18 separate	>0.5 to 40	<0.01 to 40	0.5 to 18	0.5 to 60	<0.5 to 8	0.5-4 (0.5-18 channelized and down conversion)
Max Instantaneous Analysis Bandwidth	Multi-octave (to 17.5 GHz)	As high as desired with equivalent reduction in resolution	Multi-octave (1 octave per unit)	50 MHz	500 MHz	~2 GHz without degradation, 17.5 GHz with degradation	0.5 to 2 depending on PW limitation	1 GHz
Frequency Accuracy	Measurement accuracy no better than analysis BW	Measurement accuracy no better than analysis BW	5-10 MHz	0.5% to 1%	0.5 to 3 MHz	±1 MHz	10 KHz	±1 MHz

Feature	Receiver Type							
	Wide-Band Crystal Video	TRF Crystal Video	IFM	Narrow-Band Superhet	Wide-Band Superhet	Channelized	Microscan	Acousto-optic
Pulse Width Range	CW to 50 ns	CW to 50 ns	CW to ~20 ns (depending on resolution)	CW to 100 ns with 20 MHz resolution	CW to 4 ns with 500 MHz resolution	CW to 30 ns (depending on resolution)	CW to 250 ns	CW to 0.5 μ s
Frequency Resolution	~400 MHz (no better than BW)	25 MHz	1 MHz	<0.1 MHz	100-500 MHz	10-125 MHz (less with freq vernier)	1 MHz	0.5 to 1 MHz
Sensitivity (dBm)	-40 to -50 (no preamp) -80 (with preamp)	Better than -80 with preamp	-40 (no preamp) -75 (preamp) 4 GHz BW	-90, 1 MHz BW	-80, 500 MHz BW	-70, 10-50 MHz BW	-90, 5-10 MHz BW	-70 to -80
Maximum Dynamic Range (dB)	70	70-80	80 (w/preamp) 100+ (saturated)	90	60	50-80	40-60	25-35
Tuning Time	-	50 ms	-	1.0 s (1 octave)	.12 s (200 MHz band)	-	0.3 μ s LO scan time	0.5 ms (integration time)
Signal ID Time	100 ns	50 ms	2-10 ms	~0.1 s	-	2.10ms	~1 μ s	-
Minimum Weight (lb)	20 (with processor)	30	<20 (octave unit) 65-75 (full coverage)	60-75	35 (tuner only)	1309-200 for 0.5 to 18 GHz coverage	25	29-55
Size / Minimum Volume (in ³)	Small 300 (w/processor)	Small 375	Sm/Moderate 600-1000 ~100 miniaturized	Moderate 1500-3000	Moderate Several thousand	Large 4000-8000 (0.5-18 GHz coverage)	Moderate 1200-2000	Small 800-1900
Minimum Power (W)	100 (with processor) <10 without processor	60 (without processor)	~50 (octave unit)	150	150 (tuner only)	350 to 1200 for 0.5 to 18 GHz coverage	70-80	200
Cost	Low	Low/Moderate	Moderate	Moderate/High	Moderate/High	High	Moderate/High	Low/Moderate